



GlasStile S

Motorised Entrance Gate for Internal Installation

Entrance gates are designed to combine smooth function and sophisticated appearance with security in settings where design is important. Entrance gates are completely silent and provide easy passage and high through-put. Designed to reduce the barrier effect and create a welcome atmosphere, visitors can immediately see how and where they should enter.

GlasStile S consists of a grained or polished stainless steel column with one glass leaf.

A wide selection of glass dimensions and styles is available to create a two-leaf passage or match with the design of the SpeedStile product range.

On receiving a signal from the access control system or push button, the unit will unlock and drive through 90 degrees away from signal direction. Should the wing meet any resistance it will stop and nudge forward. If obstruction continues the unit will alarm and free wheel; an auto reset will re-establish control.

From



Bishopsgate

GUNNEBO[®]
For a safer world

GlasStile S

Technical Specifications

Drive

Motorised, pass left or pass right. Logic Voltage 24Vac

Materials

Rotor column: 220mm dia. 304 grade grained stainless steel

Rotor wing: 10mm-thick clear toughened frameless glass panel

Power Failure / Fire Alarm

In the event of an emergency or isolation of power supply, the unit will failsafe i.e. rotor will freely turn in both directions. Input facility available for voltage free contact supplied by others to effect fire alarm fail safe state.

Additional Interface

Potential-free contact provided by either a card reader or push button input. Card reader inhibit and reset output signals available as standard.

Power Supply / Power Rating

230Vac 50Hz or 115Vac 60Hz / 250VA

Operating Temperature / IP rating / MCBF⁽¹⁾ / MTTR⁽²⁾

+5 to +40°C (RH 95% not condensing) / IP 20 / 2M cycles / <30mn

⁽¹⁾ Mean Cycles Between Failure

⁽²⁾ Mean Time To Repair

Flow Rates (average data, dependent upon access control system is use)

- Insertion Type Reader: 10 passages per minute
- Swipe Type Reader: 15 passages per minute
- Proximity Reader "Hands Free": 20 passages per minute

Versions

- 1000mm High Column
- 950mm High Column

Options

- Alternative finishing
- Glass leaf height and width selection
- Posts for card reader integration
- Push button control
- Remote console
- Hand-held programmer
- Push bar
- Remote control system

Main Applications

- Banking & Finance
- Corporate Offices
- Education
- Government
- Information & Technology
- Leisure & Entertainment
- Retail
- Sport Arenas

GlasStile S

Versions and Configurations: GlasStile S

Product delivered in a kit form i.e. Wings and Rotor and may require lifting equipment. Approx. Weight: 75Kg
 (For installation details, please refer to Gunnebo product CAD drawings)

1000mm High Column

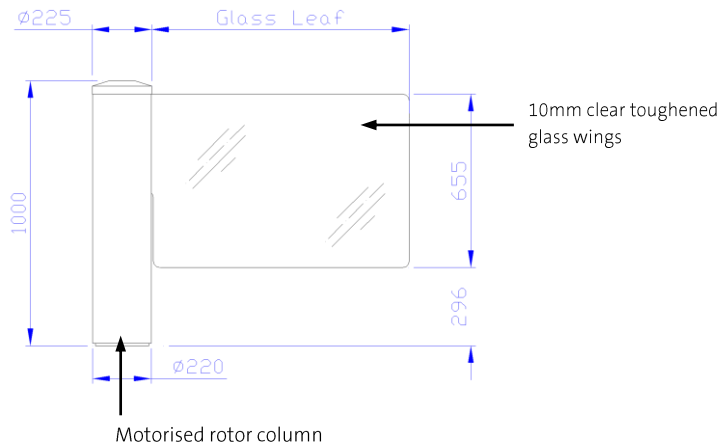

Glass Leaf Height (mm)	Glass Leaf Width Selection (mm)	Clear Opening (mm)
655	975	1025
	950	1000
	900	950
	850	900
	800	850
	750	800
	700	750
	650	700
	600	650
	550	600
	500	550

950mm High Column

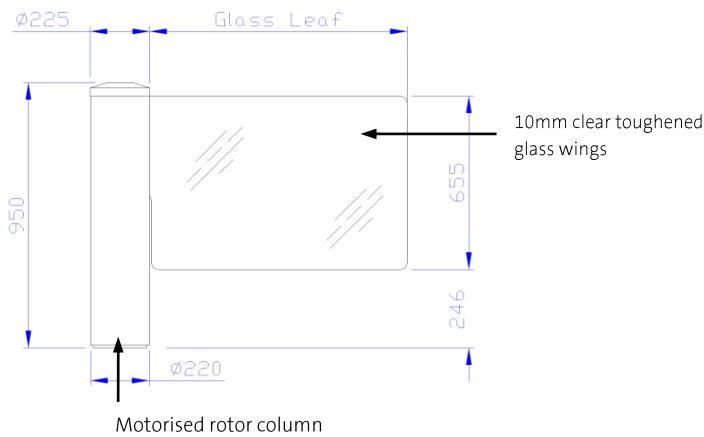

Glass Leaf Height Selection (mm)	Glass Leaf Width Selection (mm)	Clear Opening (mm)
655	975	1025
	950	1000
	900	950
	850	900
	800	850
	750	800
	700	750
	650	700
	600	650
	550	600
	500	550
1050	900	950
	850	900
	800	850
	750	800
	700	750
	650	700
	600	650
	550	600
	500	550
		450
1650	400	450
	475	525
	450	500
	425	475
	400	450

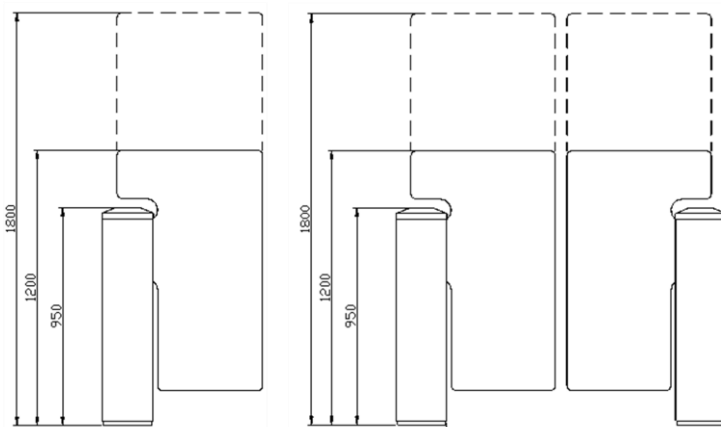

Concrete Base to specification at least fck (cube) 300N/mm² of resistance
 Base to be flat and level to +/- 5mm over footprint area. Dimensions to be > 300 x 300 x 300 deep min (units in mm)

GlasStile S

Important

- Any horizontal pipe or conduit running below the GlasStile must be at least 140mm below FFL
- Metal conduit for cables should be raised at least 50mm from foundation
- It is the customer's responsibility to ensure the structural integrity and strength of the installation location
- The dimensions given in this Product Data Sheet are for information only. In order to prepare the installation site, please refer to Gunnebo Customer Services

FOR FURTHER INFORMATION PLEASE CONTACT:



Bishopsgate Int (Nig) Ltd

52a Campbell Street

Lagos Island CBD

Lagos State 100221

Tel. [+234 \(700\) 247-4677-4283](tel:+234(700)247-4677-4283)

Email: sales@bishopsgate-nq.com

Web: www.bishopsgate-nq.com

Note: In pursuit of its policy of continuous refinement and improvement, Gunnebo reserves the right to modify design and details given in this material at any time and without notice. Images enclosed in this document are for reference purposes only.